

Endevco®

# Isotron® accelerometer Model 27BLPF

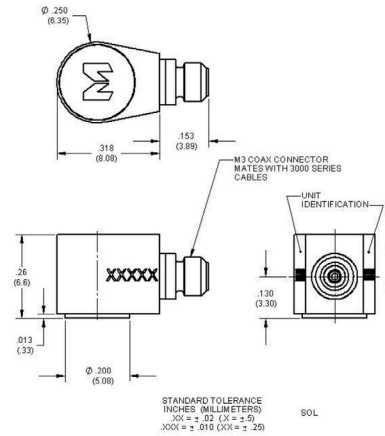
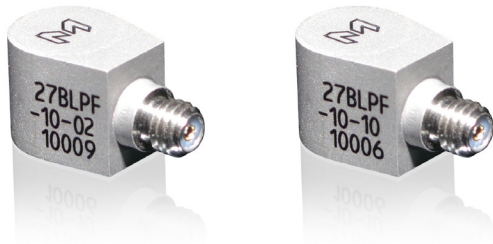

The Endevco® Model 27BLPF is a miniature IEPE high temperature (up to +175 °C) single axis accelerometer with 2-pole low pass filter. The sensor is designed for use in test and measurement applications requiring effective attenuation of high-frequency, high-g signals that can obscure the required low-frequency information and cause saturation of the electronics. Additionally, the low-pass filter provides resonance suppression. The high operating temperature of the accelerometer is a supplementary feature needed for many test and measurement applications. The model 27BLPF is packaged in a hermetically sealed body of titanium alloy with a side M3 connector. A compatible cable is provided with the unit. Power to the sensor, in the form of a constant current, travels through the same pins as the low impedance output signals.

The model 27BLPF features a sensitivity of 10 mV/g. The model number's second suffix indicates the low-pass filter corner frequency at level -3dB. Two options are currently available, the model 27BLPF-10-02 featuring a corner frequency of 2 kHz and the 27BLPF-10-10 featuring a corner frequency of 10 kHz. Other corner frequencies are available upon request.

This product is fully compliant to the European Union's Low Voltage Directive, 2006/95/EC and EMC Directive 2004/108/EC and is eligible to bear the CE Mark.

Endevco brand signal conditioner models 133, 2775B, 2793, 4416B, 4999, 6634C or OASIS 2000 (4990A-X with cards 428 and/or 433) computer-controlled systems are recommended for use with these accelerometers.

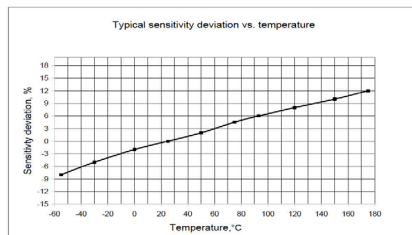
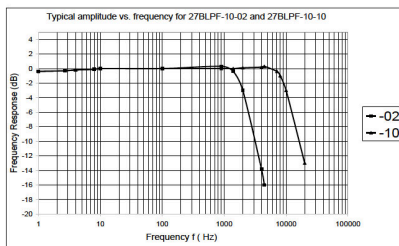

## Key features

- Low impedance output with 2-pole low pass filter
- Rated for continuous use up to +175°C (347°F)
- Lightweight (less than 1.0 gram)
- Adhesive mounted
- 27BLPF-10-02-R and 27BLPF-10-10-R available as replacement sensors

## Meggitt Sensing Systems

Our measurement product competencies:

Piezoelectric accelerometers | Piezoresistive accelerometers | Isotron accelerometers | Variable capacitance accelerometers | Pressure transducers | Acoustic sensors | Electronic instruments | Calibration systems | Shakers | Modal hammers | Cable assemblies

**MEGGITT**  
smart engineering for  
extreme environments

Endevco®

# Isotron® accelerometer

## Model 27BLPF

### Specifications

The following performance specifications conform to ISA-RP-37.2 (1964) and are typical values, referenced at +75°F (+24°C) and 100 Hz, unless otherwise noted. Calibration data, traceable to National Institute of Standards and Technology (NIST) is supplied.

Dynamic characteristics	Units	-10-02		-10-10
Range	g		±500	
Voltage sensitivity				
Typical	mV/g		10	
Tolerance	%		10	
Amplitude response				
±5%	Hz	2 to 1000		2 to 5000
±1 dB	Hz	1 to 1400		1 to 7000
Resonance frequency, minimum	Hz		45 000	
Low-pass filter corner frequency [-3 dB]	kHz	2 ±0.2		10 ±1
Low-pass filter roll-off	dB/Octave		10-12.5	
Temperature response			See typical curve	
Sensitivity deviation			Negative absolute value <20% at -67°F [-55°C] [ref 77°F [25°C]]	
Sensitivity deviation			Positive absolute value <30% at +347°F [+175°C] [ref 77°C [25°C]]	
Transverse sensitivity	%		<5	
Amplitude linearity	%		<2	
<b>Output characteristics</b>				
Output polarity			Acceleration directed into base produces positive output	
DC output bias voltage [1]	Vdc		+12 to +13 at room temperature +6 to +16 over temperature range See connection diagram	
Output connection				
Output impedance				
2 mA to 3 mA	Ω		<300	
4 mA to 10 mA	Ω		<100	
Full scale output	Vpk		±5	
Saturation level at 5Vpk output				
100 Hz	gpk	500		500
1 kHz	gpk	500		500
2 kHz	gpk	≥700		500
5 kHz	gpk	≥1000		500
10 kHz	gpk	≥1000		≥700
40 kHz (resonance frequency)	gpk	≥1000		≥1000
Noise floor				
Broadband [0.1 Hz to 10 kHz]	mg rms		≤8	
Spectral:				
1 Hz	mg / √ Hz		≤2	
10 Hz	mg / √ Hz		≤0.7	
100 Hz	mg / √ Hz		≤0.3	
1 kHz	mg / √ Hz		≤0.2	
Overload recovery [2x full scale]	mg μs		<10	
Grounding			Signal ground connected to the case	
<b>Power requirement</b>				
Current requirement	mA		+2 to +8	
Voltage supply	Vdc		+24 to +30	
Supply noise	mV/pk		<1	
Warm-up time (time to reach 90% of final bias)	sec		<10	
<b>Environmental characteristics</b>				
Temperature range			-67°F to +347°F [-55°C to +175°C]	
Humidity			Hermetically sealed	
Sinusoidal vibration limit (without damage)	g pk		±1000	
Shock limit (without damage) [2]	g pk		5000	
Base strain sensitivity at 250μ strain	eq. g/μstrain		0.13	
Thermal transient sensitivity	eq. g pk/°F		0.16	
Electromagnetic noise [at 100 Gauss]	eq. g pk/Gauss		0.0001	
<b>Physical characteristics</b>				
Dimensions			See outline drawing	
Weight	oz (gram)		0.028 (0.8)	
Case material			Titanium alloy 6Al-4V	
Connector [3]			M3 receptacle	
Mounting [4] [5]			Adhesive	
<b>Calibration</b>				
Supplied				
Sensitivity	mV/g			
Transverse sensitivity	%			
Frequency response	Hz	20 to 2200		20 to 11 000
Bias	Vdc			

Endevco®

# Isotron® accelerometer Model 27BLPF

## Accessories

Product	Description	27BLPF	27BLPF-R
3053VM1-120	Cable assembly, 10ft	Included	Optional
2943M1	Removal tool	Included	Optional
2987M9	Isolation mount	Included	Optional
32279	Mounting wax	Included	Optional
133	Signal conditioner	Optional	Optional
2775B	Signal conditioner	Optional	Optional
2793	Isotron® signal conditioner	Optional	Optional
4416B	Signal conditioner	Optional	Optional
6634C	Signal conditioner	Optional	Optional
4999	Signal conditioner	Optional	Optional
4990A-X	OASIS 2000 computer controlled system with cards 428, 433 and/or 482B	Optional	Optional

## Notes

- +24 Vdc must be available to the accelerometer to ensure full scale operation at temperature extremes.
- Shock pulses of short duration may excite transducer resonance. Shock level above the sinusoidal vibration limit may produce temporary zero shift that will result in erroneous velocity or displacement data after integration.
- Mates with Endevco model 3053VM1 cable.
- Depending on the dynamic and environmental requirements, adhesives such as petro-wax, hot-melt glue, and cyanoacrylate epoxy (super glue) may be used to mount the accelerometer temporarily to the test structure.
- To remove an epoxy mounted accelerometer, first soften the epoxy with an appropriate solvent and then twist the unit off with the supplied removal wrench. Damage to sensors caused by inappropriate removal procedures are not covered by Meggitt's warranty.
- Maintain high levels of precision and accuracy using Meggitt's factory calibration services. Call Meggitt's inside sales force at 800-982-6732 for recommended intervals, pricing and turnaround time for these services as well as for quotations on our standard products.

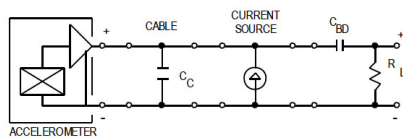
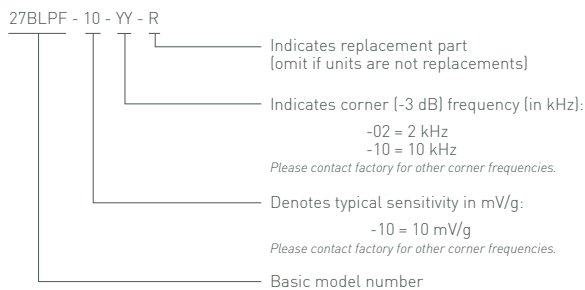

## Contact

### Meggitt Sensing Systems

14600 Myford Road  
Irvine  
CA 92606, USA  
Tel: +1 (949) 493 8181  
Fax: +1 (949) 661 7231

www.endevco.com  
www.meggitt.com



Continued product improvement necessitates that Meggitt reserve the right to modify these specifications without notice. Meggitt maintains a program of constant surveillance over all products to ensure a high level of reliability. This program includes attention to reliability factors during product design, the support of stringent Quality Control requirements, and compulsory corrective action procedures. These measures, together with conservative specifications have made the name Endevco synonymous with reliability. 100114

**MEGGITT**  
smart engineering for  
extreme environments